

1. Before installing, dismantle the parts below from the body.

※ Dismounted parts are not used when Chain Basket is installed.

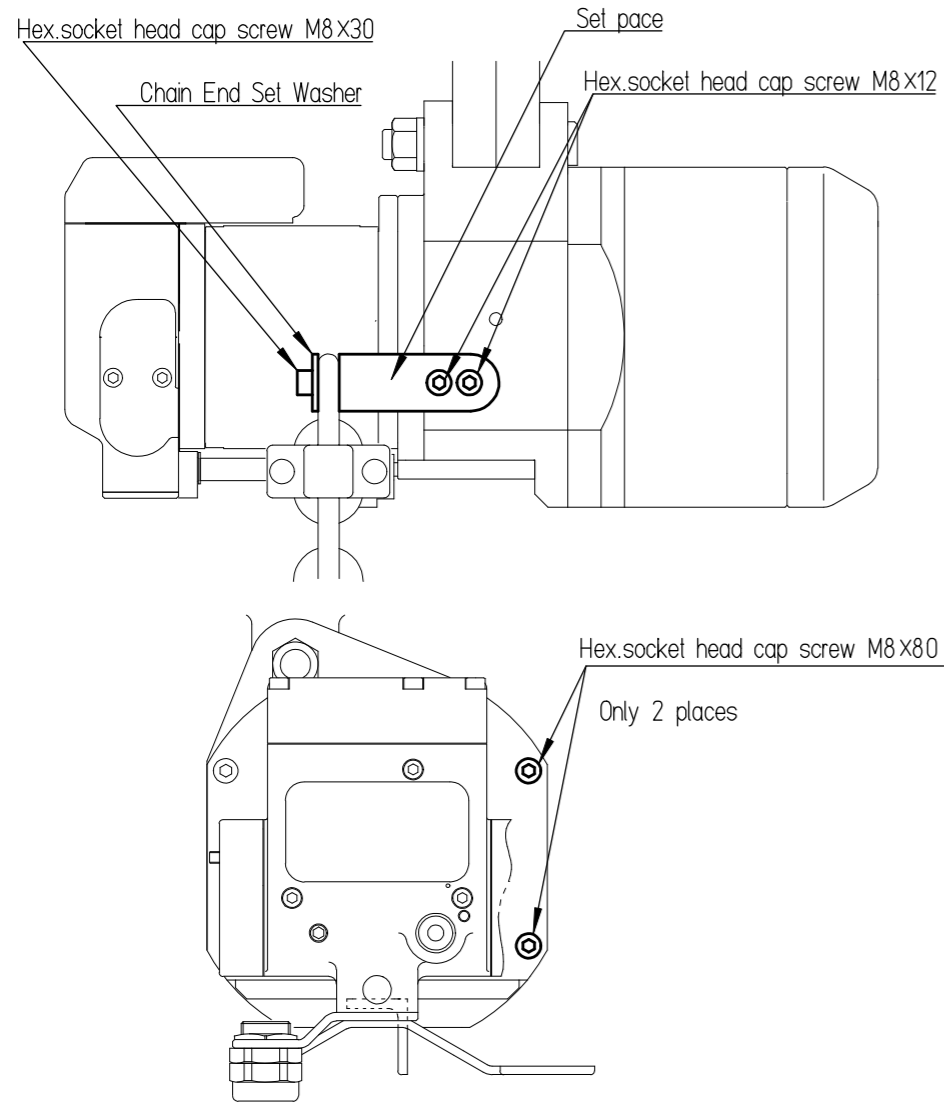

2. As shown by a diagram, install End washer at chain.

Dismount Chain Down Stopper for the chain end once. Then, put Wind Washre through chain and install Chain Down Stopper again at 2nd link chain from the end.

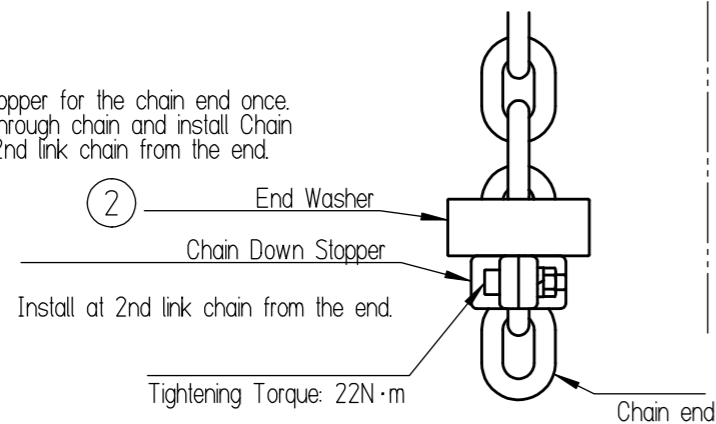

3. As shown by a diagram, install the Chain Basket.

※ At factory shipment, the parts for X-type Chain Basket is preassembled except installing to the body.

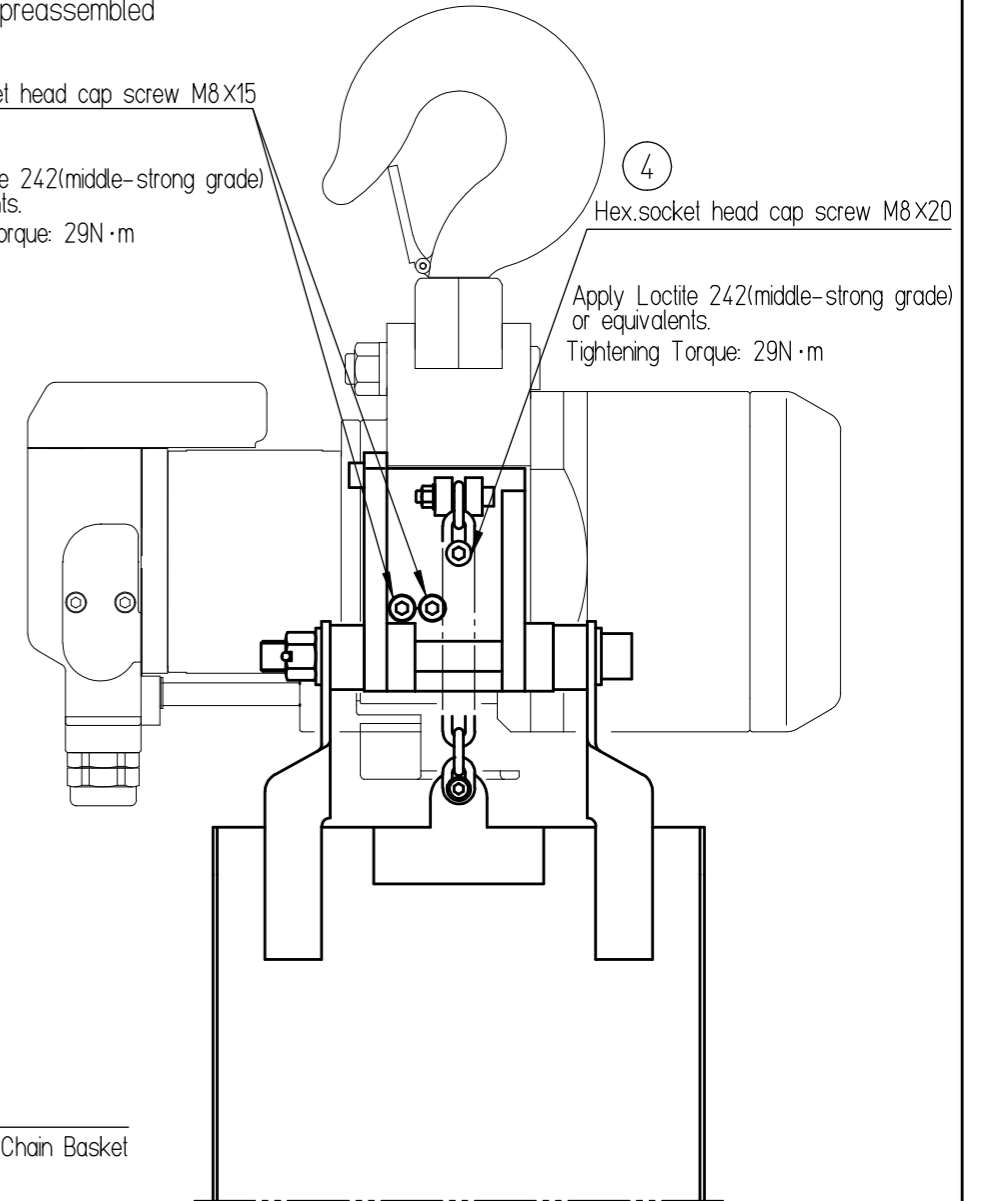
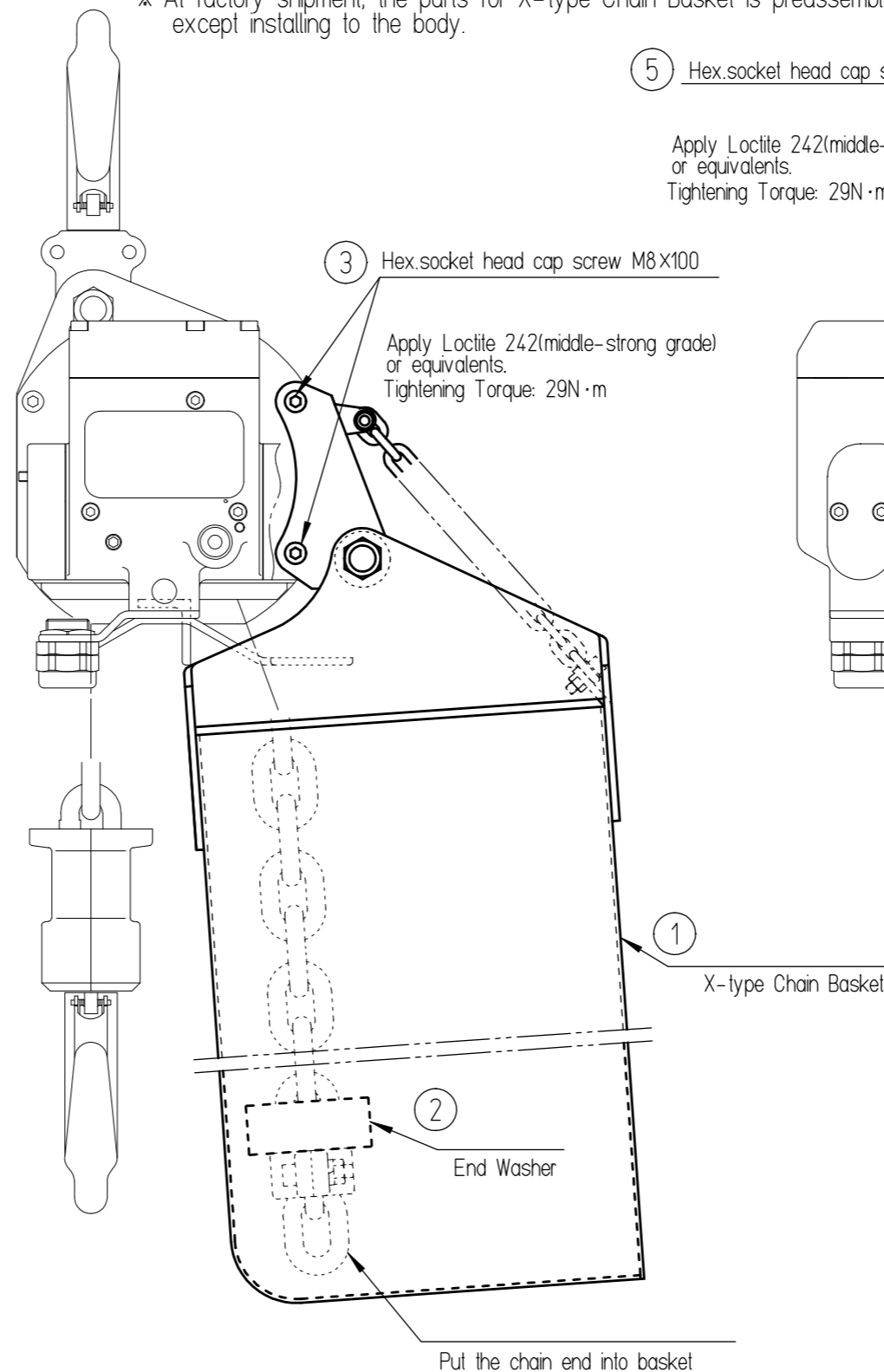

1	X-type Chain Basket	1
2	End Washer	1
3	Hex.socket head cap screw M8x100	2
4	Hex.socket head cap screw M8x20	1
5	Hex.socket head cap screw M8x15	2